

VERMEIREN

Carpo Limo

INSTRUCTION MANUAL





Contents

1	Product description	3
1.1	Intended use	3
1.2	Safety instructions	4
1.3	Technical specifications	5
1.4	Accessories	6
1.5	Components	7
1.6	Location identification plate	7
1.7	Explanation of symbols	8
2	Use	8
2.1	Remarks on electromagnetic compatibility (EMC).....	8
2.2	Carrying the scooter.....	9
2.3	Assembly and disassembly of the scooter	10
2.4	Operating the brakes	11
2.5	Transfer in and out the scooter	11
2.6	Correct position in the scooter	11
2.7	Driving the scooter	11
2.8	Driving the scooter on ramps.....	14
2.9	Driving the scooter over steps	15
2.10	Operator control.....	15
2.11	Neutral	16
2.12	Transport in the car	17
2.13	Automatic power shut down.....	18
2.14	Charging the batteries	18
3	Installation and adjustment.....	19
3.1	Tools	19
3.2	Manner of delivery	20
3.3	Adjusting the steering unit.....	20
3.4	Adjusting the seat	20
3.5	Adjusting the rear view mirrors	22
3.6	Adjusting the armrests	22
3.7	Tyre changing	23
3.8	Thermal fuses	24
3.9	Anti-tipping	24
3.10	Changing the battery.....	25
4	Maintenance	25
5	Declaration of conformity	25



Preface

First of all we want to thank you for putting your trust in us by selecting one of our scooters.

The expected lifetime of your scooter is strongly influenced by the care and maintenance of the scooter.

This manual will help you get acquainted with the operation of your scooter.

Following the user instructions and the maintenance instructions are an essential part of the warranty.

This manual reflects the latest product developments. Vermeiren has the right to introduce changes without the obligation to adapt or replace previously delivered models.

For any further questions, please consult your specialist dealer.



1 Product description

1.1 Intended use

The scooter is intended to comfortably transport people.

The scooter is designed to transport 2 adult people only, no goods may be transported with the scooter, nor any persons under the age of 16 may drive with the scooter.

Neither should it be used by people obviously suffering from physical or mental limitations that render them incapable of safely handling the scooter in traffic.

These limitations could involve:

- hemiplegics or paraplegics
- loss of limbs (arm amputation)
- limb defects or deformations (if resulting in reduced equilibrium and steering abilities)
- contractures or damaged joints (if resulting in reduced equilibrium and steering abilities)
- balance disturbances
- cachexia (decrease in muscle)
- mental disorders
- damage to the cerebral cortex owing to psychological disorders
- visual impairment

The scooter is classified as class B.

The scooter is suited for outdoor use by the occupant.

When providing for individual requirements:

- body size and weight
- physical and psychological condition
- residential circumstances
- environment

should be taken into consideration.

Your scooter should be used on flat surfaces where all four wheels are touching the ground and where there is sufficient contact to propel the wheels equally.

You should practice for use on uneven surfaces (cobblestones, etc.), slopes, curves and to get past obstacles (curbs, etc.).

The scooter should not be used as a ladder, nor is it a transport for heavy or hot objects.

When using your scooter on streets or footpaths, local laws and regulations apply.

The scooter can be used on sidewalks, urban road. Under no circumstances the scooter may be used for driving on larger roads or expressways.

Use only Vermeiren approved accessories.





























The manufacturer is not liable for damage caused by the lack of or improper service or as a result of not following instructions from this manual.

Compliance with the user and maintenance instructions are an essential part of the warranty conditions so we recommend that you read the following pages very carefully.

Visually impaired people can contact the dealer for the instructions for use.



1.2 Safety instructions

-  Use only Vermeiren approved accessories.
-  Before getting on or off, taking apart or transporting your scooter, turn the start key to the “off” position.
-  When transporting the scooter, no persons may be transferred along with it.
-  Test the effects on the handling of the scooter when its center of gravity is shifted, for example on up or down gradients, on laterally sloping ground or when driving over uneven terrain.
-  Do not drive on roads with heavy traffic or roads that are muddy, gravelly, bumpy, narrow, snowed over, icy or canal towpaths not guarded by any fence or hedge.
-  Keep away from places where you might get the wheels stuck.
-  Pay attention that your clothes do not tangle in the wheels.
-  When picking up objects lying in front of, next to, or behind the scooter, take care that you do not lean too far sideways: risk of tipping over.
-  Avoid putting your scooter into the free-wheeling position on slopes.
-  Never reverse uphill.
-  Reduce speed when you go round corners.
-  Do not take the scooter onto escalators.
-  While driving, hold the handgrips with both hands.
-  Put your legs and feet on the surfaces provided for them during the drive.
-  Do not use your scooter in snowing, misty or heavy windy conditions.
-  When storing or parking your scooter outside, protect it with a shrouding cover against humidity.
-  High levels of humidity or very cold conditions can reduce the performance of your scooter.
-  Use your scooter strictly in accordance with regulations. Avoid driving straight over obstacles (e.g. step, edge of the curb) or down from high ledges.
-  Obey traffic regulations when driving on public roads. Please take other road-users into consideration.
-  As is the case with any other vehicle, you must never be under the influence of alcohol or medicine while driving your scooter. This also applies to indoor driving.
-  When traveling outdoors, adapt your driving to weather and traffic conditions.
-  When driving in the dark, wear bright clothing or clothing with reflectors to be more visible, and make sure that the reflectors on the scooter are clearly visible and drive with lighting on.
-  Make sure that the lights of your scooter are free from dirt and/or other objects that could hide them.
-  Never use your scooter as a seat in an automobile or other vehicle.
-  Check that the profile depth of the tyres is adequate.
-  If your scooter has pneumatic tyres, be careful to inflate them to the correct pressure (see *pressure indication on the tyres*) for optimal steering and stability of the scooter.
-  Make sure that the maximum load of the scooter is not exceeded.
-  Do not overload the shopping basket. The maximum load of the shopping basket is 5 kg.
-  Do not overload the storage tray. The maximum load of the storage tray is 1 kg.

1.3 Technical specifications

Technical terms below are valid for the scooter in standard settings and optimum environmental conditions. If other accessories are used, the tabulated values will change. Changes in outdoor temperatures, humidity, uphill, downhill, soils and battery levels can reduce output.

Brand	Vermeiren		
Address	Vermeirenplein 1/15, B-2920 Kalmthout		
Type	Rear wheel drive scooters, Class B		
Maximum load	180 kg		
Model	Carpo Limo		
Description	Minimum dimensions	Maximum dimensions	
Max. speed	13 km/h		
Continuous driving distance range*	41 km (battery: 90 Ah)		
Length	2250 mm		
Width	700 mm		
Height	1240 mm		
Folded / dismantled length	Not foldable		
Folded / dismantled width	Not foldable		
Folded / dismantled height	710 mm (seat removed; steering unit folded)		
Total mass	182 kg		
Mass of heaviest part (that can be dismantled or removed)	154,2 kg (without seat) or 107,2 kg (without seat and batteries)		
Masses of parts that can be dismantled or removed.	Seat: 27,8 kg; Batteries: 23,50 kg		
Static stability downhill	9,5°		
Static stability uphill	8,5°		
Static stability sideways	10,5°		
Dynamic stability	6°		
Maximum safe slope	6°		
Obstacle climbing	50 mm		
Ground clearance	100 mm		
Seat plane angle	5°		
Effective seat depth	450 mm		
Seat surface height at front edge (measured from ground)	490 mm	565 mm	
Seat surface height at front edge (measured from footplate)	280 mm	355 mm	
Height footplate	210 mm		
Backrest angle	15° (Not foldable)		
Backrest height	430 mm		
Distance between armpad and seat	200 mm	244 mm	
Front location of armrest structure	420 mm		
Motor	Nom. 750 Watt, electromagnetic brakes		
Batteries	90 Ah		
Controller	140A		
Nominal voltage (battery)	2 x 12V ---		
Degree of protection	IPX4		



Brand	Vermeiren		
Address	Vermeirenplein 1/15, B-2920 Kalmthout		
Type	Rear wheel drive scooters, Class B		
Maximum load	180 kg		
Model	Carpo Limo		
Description	Minimum dimensions	Maximum dimensions	
Battery charger	8 Amp (external)		
USB connection	Yes		
Battery charger protection class	IPx1		
Battery charger insulation class	II		
Minimum turning diameter	6180 mm		
Reversing width	3410 mm		
Diameter rear wheels (number)	100 x 65 mm-9 air (2)		
Tyre pressure, rear (driving) wheels	Max. 1,7 bar		
Diameter steering wheels (number)	100 x 65 mm-9 air (2)		
Tyre pressure, steering wheels	Max. 1,7 bar		
Handle bar	Delta, Speed control lever		
Lights	Serial		
Indicator light	Serial		
Mirrors	Optional		
Storage and use temperature	+5 °C to +41 °C		
Operating temperature of the electronics	-10°C to +40°C		
Storage and use humidity	30%		
<p>We reserve the right to introduce technical changes. Measurement tolerance ± 15 mm / 1,5 kg / °.</p> <p>* The theoretical driving distance will be reduced if the scooter is used frequently on slopes, rough ground or to climb curbs. Maximum driving distance is based on an ambient temperature of 20°C, a 100 kg driver and a brand new fully recharged battery by a constant driving speed at 15 km/h with 70% battery power discharged.</p>			

Table 1: Technical specifications

1.4 Accessories

The following accessories are available for the scooters Carpo Limo:

- Spare wheel (mounted on the back of the scooter)
- **WARNING: Risk of injury - Be sure that crutches are attached very well and cannot fall on the user.**

Crutch holder

1.5 Components

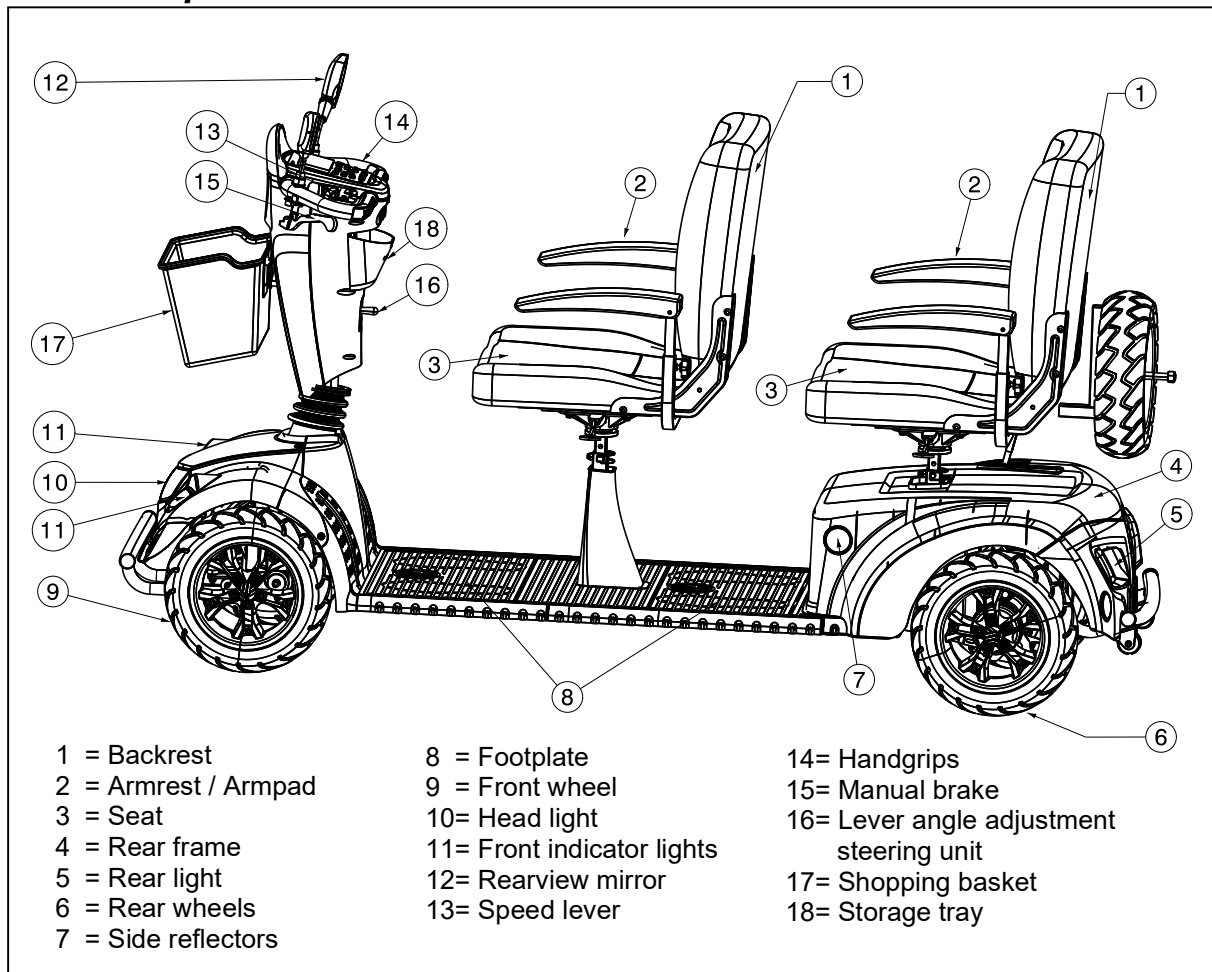

1.6 Location identification plate

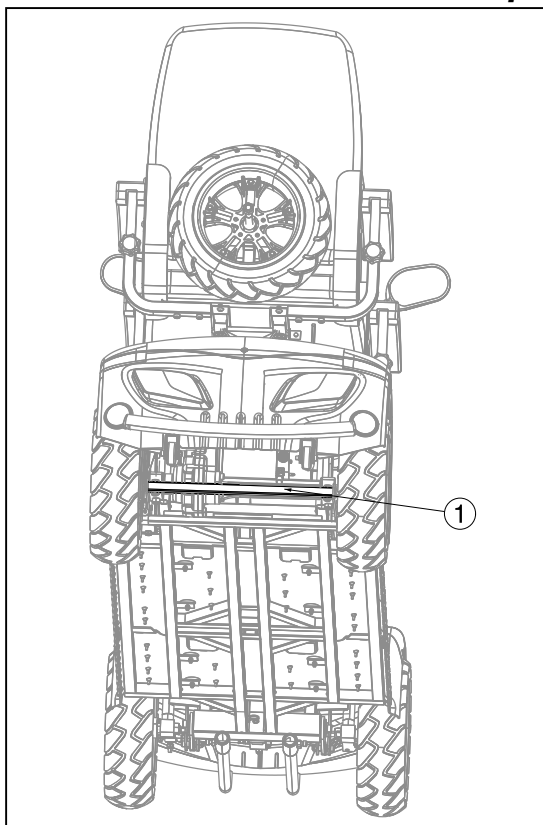

The location of the identification plate ① is on the back side of the scooter just below the rear cover.

You can also find an identification plate under the battery cover.



1.7 Explanation of symbols



Maximum mass



Outdoor use



Indoor use (only for battery charger)



Separate recovery and recycling of electric and electronic devices (only for battery charger)



Protection class II



Maximum safe slope



CE conformity



Maximum speed



Not intended to be used as a seat in a Motor vehicle



Type designation



Warning: Do not Pinch hands / fingers

2 Use

This chapter describes the everyday use. **These instructions are for the user and the specialist dealer.**

The scooter is delivered fully assembled by your specialist dealer. The instructions intended for the specialist dealer on how to set up the scooter are given in § 3.

2.1 Remarks on electromagnetic compatibility (EMC)

Your scooter has been tested according ISO 7176-21.

We wish to point out that sources of electromagnetic waves (e.g. cell phones) are liable to create interferences. The electronics of the scooter itself could affect other electric appliances too.

To reduce the effect of electromagnetic sources of interference, please read the following warnings:

- ⚠ WARNING: The scooter might disturb the operation of devices in its environment that emit electromagnetic field.**
- ⚠ WARNING: The driving performance of the scooter can be influenced by electromagnetic fields (e.g. electricity generators or high power sources).**
- ⚠ WARNING: Avoid using any portable TV or radio in the immediate environment of your scooter for as long as it is turned on.**
- ⚠ WARNING: Avoid using any transmitter-receiver or cell phones in the immediate environment of your scooter for as long as it is turned on.**
- ⚠ WARNING: Check the area for transmitter masts and avoid using the scooter close to them.**



⚠ WARNING: If involuntary movements or braking occur, turn off the scooter as soon as it is safe to do so.

Interfering electromagnetic fields may have a negative effect on the scooter's electronic systems. These can include:

- Disengagement of the engine brake
- Uncontrollable behavior by the scooter
- Unintentional steering movements

In the presence of very strong or enduring interfering fields, the electronic systems could even break down entirely or suffer permanent damage.

Possible sources of radiation include:

- Portable receiver and transmitter installations (receiver and transmitter with fixed antenna mounted directly on the transmitting unit)
 - Transmitting and receiving sets
 - Cell phones or "walkie talkie"
 - portable TV, radio and navigation devices
 - other personal transmitting devices
- Mobile medium-range transmitting and receiving devices (e.g. car antennas, with the antenna mounted on the outside of the vehicle)
 - Fixed transmitting and receiving sets
 - Fixed mobile transmitting and receiving devices
 - Fixed radio, TV and navigation systems
- Long-range transmitting and receiving devices
 - Radio and television towers
 - Amateur radio sets

Other home devices like CD player, notebook, cordless phones, AM/FM radios, electric shavers and hair dryers, so far as we know, will have no influence provided that they function perfectly and their cabling be in an excellent condition. Please conform to the operating instructions accompanying such electric instruments to ensure trouble free operating of your scooter.

1. Do not operate hand-held (transceivers-receivers), such as citizens band (CB) radios, or turn ON personal communication devices, such as cellular phones, while the powered vehicle is turned ON;
2. Be aware of nearby transmitters, such as radio or TV stations, and try to avoid coming close to them;
3. If unintended movement or brake release occurs, turn the powered vehicle OFF as soon as it is safe;
4. Be aware that adding accessories or components, or modifying the powered vehicle, may make it more susceptible to EMI (Note: There is no easy way to evaluate their effect on the overall immunity of the powered vehicle);

The intensity of the interfering EM energy can be measured in volts per meter (V/m). Each powered vehicle can resist EMI up to a certain intensity. This is called its "immunity level". The higher the immunity level, the greater the protection. At this time, current technology is capable of achieving at least a 20 V/m immunity level, which would provide useful protection from the more common sources of radiated EMI. This powered vehicle model as shipped, with no further modification, has an immunity level of 20 V/m without any accessories.

2.2 Carrying the scooter

The weight of the frame and steering unit is 154,2 kg (with batteries) or 107,2 kg (without batteries). This is very heavy to carry.

The best way to carry the scooter is to make use of neutral mode of the scooter. Place the scooter in neutral and roll the scooter to the desired place.

If this is not possible you can carry the scooter by following steps:

1. Switch the scooter off.
2. Remove loose parts (seat and batteries).
3. Store loose parts in a safe place.
4. Carry the frame + steering unit with 2 or 3 persons to the desired place. Take the frame on the chassis, and not by the bumpers or the plastic parts. Only on the fixed parts from the frame.

2.3 Assembly and disassembly of the scooter

- ⚠ WARNING: Risk of injury - Make sure that all movable parts are assembled properly.**
- ⚠ WARNING: Risk of injury - Assembly and disassembly must be done by trained personnel (e.g. specialist dealer).**
- ⚠ WARNING: Risk of injury - Be careful not to cut or bruise yourself with the cables.**
- ⚠ WARNING: Risk of injury - Turn the scooter off before disassembly.**
- ⚠ CAUTION: Risk of pinching - Do not place fingers between the components of the scooter.**

To disassemble, please proceed as follows:

- Switch the scooter off.
- Remove the seat (see "Adjusting the seat" chapter).
- Lift off the rear plastic cover of the batteries.

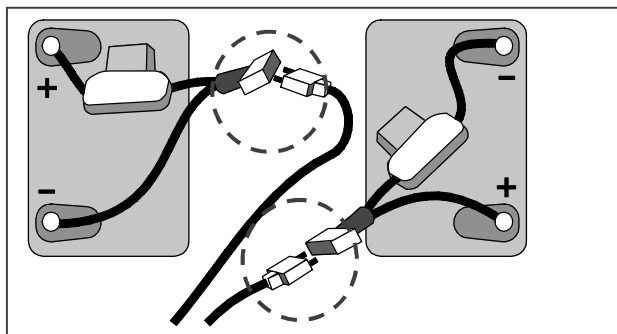

- Loosen the straps used to fasten the batteries in place.
- Unplug all battery plugs (not the pole connectors) and all cable plug- and socket connections.
- Lift the batteries out.
- Fold the steering unit down.

To reassemble, please proceed as follows:

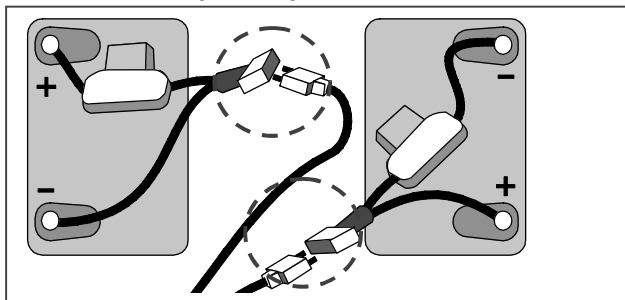

- Move the steering unit upwards.
- Put the batteries back in and connect to the battery plugs (plugs of the same color go together).
- Use the straps to tighten the batteries in such a way that they will not move, even during drives.
- Mount the rear plastic cover.
- Mount the seat (see "Adjusting the seat" chapter).

2.4 Operating the brakes

To apply the electromagnetic brakes:

1. Let go of the speed or drive lever, the electromagnetic brake in the motor will be activated, the scooter will stop.

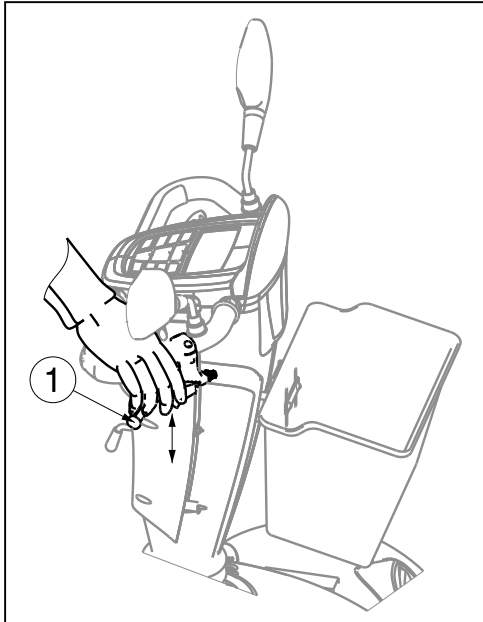

To apply the manual brakes (optional):

1. Pull the brake lever ① towards the handgrip.
2. Release the brake lever ①.

The manual brake tightness can be adjusted by the brake cable adjuster.

2.5 Transfer in and out the scooter

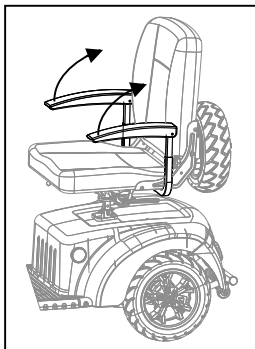

1. Park the scooter as close as possible to the place where you want to transfer.
2. Check that the control panel (scooter) is switched off.
3. Put the armpad on the side you want to transfer upwards.
4. Transfer to / from the seat of the scooter.

2.6 Correct position in the scooter

Some recommendations for a comfortable use of the scooter:

1. Position your backside as close as possible to the backrest.
2. Make sure your upper legs are horizontal.

2.7 Driving the scooter

- ⚠ WARNING: Risk of burns – Be careful when driving in hot or cold environments (sunshine, extreme cold, saunas, etc.) for a sufficient amount of time and when touching - Surfaces can assume the environment temperatures.**
- ⚠ WARNING: Risk of unsafe settings - Use only the driving characteristics described in this manual.**

2.7.1 Preparing the scooter for use

When you use your scooter for the first time, make sure that it is standing on level ground. All wheels must be in contact with the ground.

1. For first time use, fully recharge the batteries.
2. Make sure that the motor is engaged.



3. Set the steering unit in the most comfortable position for yourself and make sure it has been secured properly.
4. See that the seat has been locked in the driving position.
5. Sit down on the seat and verify that both armrests are folded down so you can rest your arms on them.
6. Insert contact key and turn to the right, please wait for at least 3 seconds before you press the speed lever otherwise you have a "delay protection" alarm. If necessary, turn on the headlights.
7. Check the battery indicator and see that there is enough power for your trip. If not enough capacity recharge the batteries before departure.

Now put the speed control on the operator control to the minimum position. Your scooter is now ready for use. Only use higher speed setting when you are confident that you can easily operate and control your scooter.

Before using the scooter in busy or potentially dangerous areas, familiarize yourself with the operation of your scooter. Please practice in a wide and open area like a park.

2.7.2 Handling after usage

Before getting off from your scooter, make sure that all four wheels touch the ground simultaneously. Next turn the key to the "OFF" (charge indicator goes out) to turn off the integrated light.

2.7.3 Parking the scooter

Once your scooter has been turned off, no command can be sent to the driving system. You will be unable to deactivate the electromagnetic brakes before turning on your scooter again. Always park your scooter on sites that are well guarded or clearly visible.

2.7.4 Your first trip

⚠ WARNING: Control your scooter - Accustom yourself with the driving behavior of your scooter.

⚠ WARNING: Control your scooter - Do not use both sides of the speed lever simultaneously. This might leave you unable to control your scooter.

⚠ WARNING: Control your scooter, risk of injury - Do not adjust the speed while you are driving.

⚠ WARNING: Risk of injury - Be sure no people or objects are behind you while reversing the scooter.

- Driving

Once you are seated on your scooter and have started it as described above, take hold of the handgrips with both hands, put your thumbs to push the speed lever in the required direction, i.e.:

PUSH ACTION BY THE RIGHT HAND	=	FORWARD MOVEMENT
PUSH ACTION BY THE LEFT HAND	=	BACKWARD MOVEMENT

When you have pressed 3 seconds on the forward / reverse switch the push actions shall be switched.

PUSH ACTION BY THE RIGHT HAND	=	BACKWARD MOVEMENT
PUSH ACTION BY THE LEFT HAND	=	FORWARD MOVEMENT

While using your scooter indoor, do not put your scooter in the highest speed.

- Driving on the pavement

Ensure the limit switch is set to the slowest setting when using the scooter on the pavement. The maximum speed to drive on the pavement depends from country to country. Check the traffic law from the relevant country.

The limit switch can be set to the fastest setting for use on the road or on private ground.

- Braking

To brake, let go of the speed/drive lever, which will let it return to the zero position and slow down your scooter to a gentle stop. Practice pulling away and braking to get accustomed to the scooter. You need to be able to estimate how your scooter will react when you drive or brake.

Do not turn your scooter "OFF" while driving as this will lead to an emergency stop and possible risk of accident and injury.

- Driving in corners and bends

⚠ WARNING: Risk of tipping over - Reduce your speed before you enter a curve or corner.

⚠ WARNING: Risk of clamping - Always maintain an adequate distance from corners and obstacles.

⚠ WARNING: Risk of tipping over - Do not drive your vehicle in an "S" pattern or make erratic turnings.

For corners and bends, use both hands to turn the handle bar in the direction you wish to take. The front wheels will turn accordingly and steer the scooter into a new direction. It is very important that you ensure that there is enough space allowing you to go around bends and corners. Narrow passages must preferably be approached in a large curve so as to allow you to enter the narrowest part as straight from the front as possible. Bear in mind that your scooter's back part will in most cases be wider than the front part.

Take care not to enter curves and corners diagonally. By 'cutting the corner', chances are that your rear wheels will run into obstacles and destabilize your scooter.

2.7.5 Backward movement

⚠ WARNING: Control your scooter - Accustom yourself with the driving behavior of your scooter.

⚠ WARNING: Control your speed - Always go backward in the lowest speed possible.

⚠ WARNING: Risk of collision - Always look to the back when you go backward.

Rearward driving requires increased concentration and care (LEFT HAND ACTION). This explains why we have greatly reduced the speed of rearward movement in comparison with forward driving. But we still recommend that you put the speed lever on minimum when you drive backward.

Do not forget that the steering direction with rearward driving is the opposite of when you go forward, and that your scooter will turn directly in the required direction.

2.7.6 Going uphill

⚠ WARNING: Control your scooter - Accustom yourself with the driving behavior of your scooter.

⚠ WARNING: Control your scooter - Never put your scooter in neutral on slopes.

⚠ WARNING: Control your speed - Moving on slopes as fast as possible.

⚠ WARNING: Risk of tipping over - Do not exceed the maximum gradient of static stability uphill (see paragraph "Technical specifications").

⚠ WARNING: Never reverse going uphill.

Always approach slopes directly from the front and, to avoid tipping over, see that all four wheels stay in contact with the ground at all times (ramps, driveways, etc.). Always lean forward when climbing a steep gradient. Your scooter is powered through a differential. Both drive wheels should therefore stay in contact with the ground at all times. Should one of the drive wheels no longer be in contact with the ground, a safety device will cut the transmission of energy to the wheels, bringing the scooter to a halt.

If you come to a stop on a slope by letting go of the accelerator, the engine break will prevent your scooter from rolling backward. As soon as the accelerator returns to zero position, the engine break is activated.



To resume your uphill drive, push the accelerator throttle open fully to ensure the release of a sufficient amount of power. This will allow your scooter to slowly ascend the slope.

If your scooter is unable to drive up, turn the speed control up and try again.

When driving on a gradient, the battery indicator light might move up and down. This is a normal phenomenon so please do not worry.

2.7.7 Going downhill

- ⚠ WARNING: Control your scooter - Accustom yourself with the driving behavior of your scooter.**
- ⚠ WARNING: Control your scooter - Never put your scooter in neutral on slopes.**
- ⚠ WARNING: Control your speed - Moving on slopes as slow as possible.**
- ⚠ WARNING: Risk of tipping over - Avoid sharp bends.**
- ⚠ WARNING: Risk of tipping over - Do not exceed the maximum gradient of static stability downhill (see paragraph "Technical specifications").**

Always approach downhill slopes directly from the front. Slantwise approaches can lead to some of the wheels no longer staying in contact with the ground (danger of tipping over). If one of the back wheels fails to make contact, the transmission of power will be cut and the scooter come to a standstill.

The weight of the scooter will increase your downhill speed. Turn the speed control down and adjust your speed to the conditions.

Avoid sharp bends on downhill slopes. The weight of your scooter could cause your scooter to lift up on one side or even fall over around bends.

2.8 Driving the scooter on ramps

- ⚠ WARNING: Risk of injury - Do not exceed the maximum load of the ramps.**
- ⚠ WARNING: Risk of injury - Choose the correct ramps so there cannot be caused any injury or damage.**
- ⚠ WARNING: Risk of injury - Note that the considerable weight of the electric scooter generated large reverse forces when an attendant is pushing the scooter over the ramps.**
- ⚠ WARNING: Risk of injury - Be sure that the wheel height is high enough to get over the free height of the ramps. The scooter frame may not touch the ramps.**

Should you wish to use ramps to drive over an obstacle, please note the following:

1. Find out from the manufacturer what the maximum load is for the ramps.
2. Drive on the ramps at the lowest speed possible.
3. See the instructions in the chapter "your first trip".

2.9 Driving the scooter over steps

It is possible to drive with your scooter over steps from 50 mm. Please start from 500 mm to take these step.

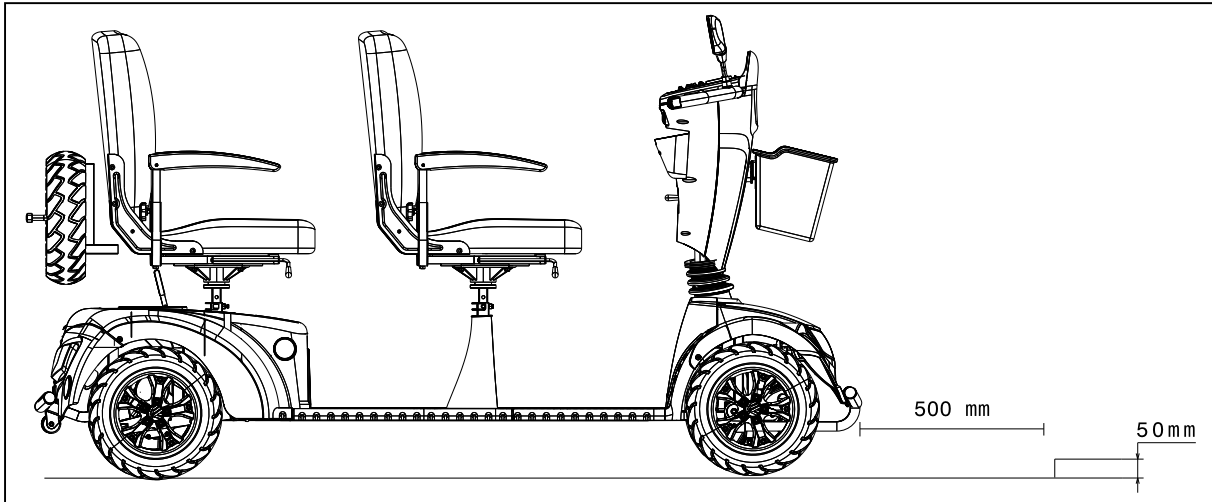

2.10 Operator control

- Put the ON/OFF key switch on, please wait for at least 3 seconds before you press the speed lever otherwise you have a “delay protection” alarm.
- Now the battery level indicator ⑬ will light up and shows the current level of your batteries.
- Now turn the speed control (⑤, ⑥, ⑦) to the desired driving speed.
- Push the drive lever with your thumbs forwards (right lever for forward movement, left lever for backward movement).
- To sound the horn, press the horn button ⑨.
- To put on the front and back lights, press the light button ⑧.
- To put on the emergency flashers, press button ⑪.
- To put on the indicator lights, press the desired button ⑩ and ⑫ (left = left indicator, right = right indicator).
- To stop the scooter loosen the speed lever under the operator control.



- 1 = Trouble indicator
- 2 = MODE button
- 3 = Reverse switch (press 3 seconds)
- 4 = SET button
- 5 = Speed control (slow)
- 6 = Speed switch
- 7 = Speed control (fast)
- 8 = Head Lights
- 9 = Horn
- 10 = Indicator (left)
- 11 = Emergency lights
- 12 = Indicator (right)
- 13 = Battery level indicator

Vermeiren is responsible for the changes in the software. For changes in the software contact Vermeiren.

2.11 Neutral

- ⚠ **WARNING:** Control your scooter - Never put your scooter in neutral while you are driving.
- ⚠ **WARNING:** Control your scooter - Never put your scooter in neutral on slopes. It may accidentally roll away.
- ⚠ **WARNING:** Risk of injury - Never pick up the electronic drive before stopping the motor/gears to prevent motor from overheating.

The scooter is fitted with a freewheel device that is accessible and operable by the attendant or the user when not sitting in the scooter. You should only use the scooter in neutral to transport the scooter or to move it out of a danger zone.

Put the scooter in neutral with the motor stop lever ① on the back side of the scooter.

- Driving
 1. Put the motor stop lever ① on drive. This will again interlock the motor and gears.
 2. Switch the ON/OFF key ON.
 3. Electronically controlled driving is now possible.
- Neutral
 1. Switch the ON/OFF key OFF.
 2. Put the motor stop lever ① on neutral (see label). This separates the motor from the gears.
 3. The scooter can now be pushed without electronic drive.

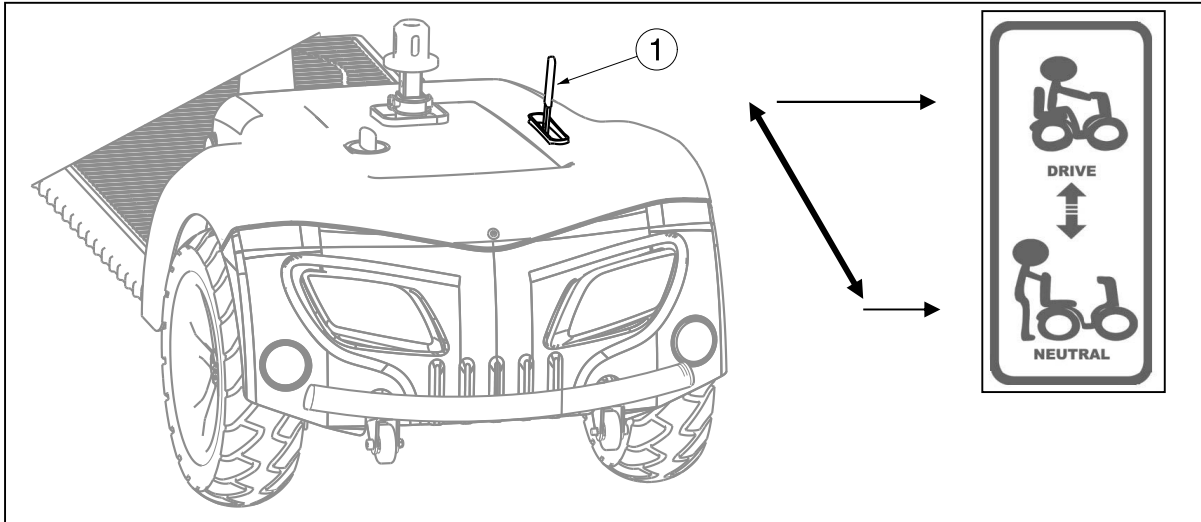

2.12 Transport in the car

- ⚠ **DANGER: Risk of injury** - The scooter is not suited for use as a seat in a motor vehicle.
- ⚠ **WARNING: Risk of injury** - Remove all loose parts prior to transportation.
- ⚠ **WARNING: Risk of injury** - No people or objects should be under the scooter, on the footplate or seat during transportation.
- ⚠ **WARNING: Risk of injury** - See that the scooter is attached properly. So you can avoid injury from the passengers during collision or sudden braking.
- ⚠ **WARNING: Chance of pinching** - Do not place fingers between the components of the scooter.

The best way to transport your scooter in the car is to drive the scooter in the car by using ramps. When you are not experienced to drive the scooter by using of ramps you can also put the scooter in neutral mode and push the scooter in the car by using ramps.

When the scooter does not fit in the car it is also possible to transport the scooter by the following steps:

1. Remove all loose parts prior to transporting (seat, etc.).
2. Store loose parts safely.
3. If possible, remove the batteries / battery boxes to save weight. (As gel batteries are closed battery systems, removal for the purpose of transportation will cause no problem.)
4. Fold the steering unit down with the angle adjustment.
5. Place the scooter in the car by 2 or 3 persons. (The weight of the frame and steering unit is 124,2 kg (with batteries) or 77,2 kg (without batteries). This is very heavy to carry).
6. Attach the frame of the scooter securely to the vehicle.



2.13 Automatic power shut down

In order to avoid accidental battery run down, your scooter is equipped with an automatic power shut down facility. If the scooter is switched on, after remaining undisturbed for a period of ten minutes it will automatically turn off. Should this occur, simply switch your scooter off and back on and it will be ready to use once again.

2.14 Charging the batteries

- ⚠ WARNING: Risk of injury - Take out the key before you start charging.**
- ⚠ WARNING: Risk of fire - Keep away from flammable objects while charging as it may lead to fire of battery.**
- ⚠ WARNING: Risk of electrical shock - Never connect or disconnect the plug or cable with wet hands while charging.**

Fully recharge your new battery before its first time use.

The light emitting diode (LEDs) in the steering unit indicates the remaining capacity of your batteries. If the battery charger is turned on and no LED's are lit, check the fuse. If the red LED does not illuminate the charger is defective, consult your specialist dealer.

Recharge the batteries on a daily basis and in a well-ventilated space, not directly exposed to sunlight. Do not charge in surroundings where it is humid or under rainfall and morning dews. If you do not do that and you keep on driving, the output of your scooter will drop very significantly (uphills, bends, dim headlights). If you ignore these signals too, your scooter will turn off. You should now immediately recharge your scooter with the accompanying battery charger. Be sure that you charge the battery fully every time.

After charging or replacing a new battery, drive the vehicle for 2-3 minutes to make sure the battery capacity is sufficient.

The battery capacity will vary by how you drive with your scooter (repeated starting, stopping, climbing, rough terrain) and will consume the capacity more quickly. In wintertime, the battery may respond more slowly and the battery range may be reduced.

Kindly also observe the accompanying operating instructions.

Primary	230V ~ / 50-60 Hz / 750 W max.
Secondary	24 V $\overline{\text{---}}$ / 8A max.
Max. battery cap.	90 Ah
Charging	Charge 80% cap. within 8 hrs

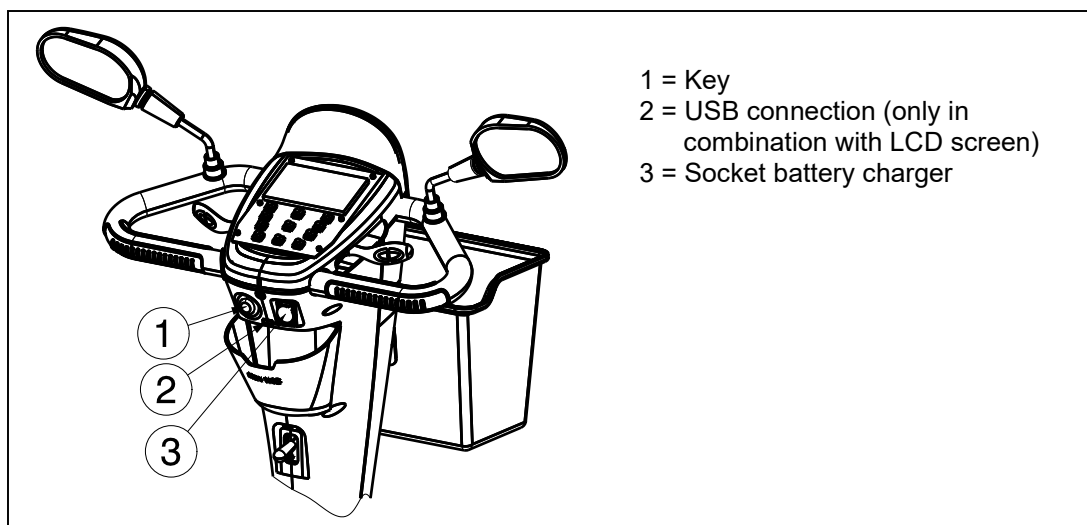

1. Turn the key ① to OFF and take it out.
 2. Open the protecting flap of the charging socket.
 3. Insert the plug of the charger into the charging socket of the scooter ③.
 4. Insert the mains plug of the charger into the power socket. Switch the charger to ON (a few models have no ON/OFF switch; with these the loading device starts operating automatically when you insert the mains cable).
 5. The charger now starts to charge and the LED (red and orange) will be lit, which indicates that it is busy charging. While charging your scooter it is not possible to run, drive your scooter because the immovable function will be activated.
 6. Once the charging process is complete, the LED (orange) turns green, thereby indicating that loading is complete. The charging duration is about 6 hours. To ensure optimum performance a 10-hour charge is recommended. But we do not recommend a charging more than 24 consecutive hours.
 7. First switch off the charger (if there is no ON/OFF switch, pull out the mains plug).
 8. Pull out the charger out the power socket.
 9. Pull out the charger plug from the charging socket of the scooter. Your scooter is again ready for use.
- Charge your scooter's batteries strictly in accordance with the description above. If you charge the batteries too early, they will gradually lose capacity, thus cutting your scooter's traveling range.
 - The manufacturer shall decline all liability for damage caused by incorrect charging.
 - Use only genuine original batteries. We do not accept any liability for damage caused by using batteries not supplied by us.
 - Do not expose the batteries to temperatures below -10° Celsius or above 50° Celsius.
 - If the batteries are opened, all liability of the manufacturer is voided as well as any claim.
 - After charging do not leave the charger socket plugged into the scooter, as this will cause a power drain on the scooter and temporarily reduce its range.

If you decide not to use your scooter for a prolonged period, you must nevertheless recharge it regularly to keep it in a running condition ready for immediate use.

- If the batteries are not being used for a prolonged period, they will discharge slowly by themselves (in-depth discharging). Then it becomes impossible to recharge them with the supplied battery charger. When batteries are not in use, they must be recharged at least every 4 to 8 weeks (depending on the charge indicator).
- Note that if you recharge the batteries too frequently, they will eventually lose their capacity irretrievably.
- Use only the supplied battery charger and no other charging equipment.
- The manufacturer shall decline all liability for damage caused by improper charging.
- In every case the charging cycle must not be interrupted. The battery charger has an indicator showing you when the charging cycle has been completed.
- Do not charge any other electrical equipment with your scooter's battery or battery charger.

3 Installation and adjustment

The instructions in this chapter are for the user and the specialist dealer.

To find a service facility or specialist dealer near you, contact the nearest Vermeiren facility. A list of Vermeiren facilities can be found on the last page.

⚠ WARNING: Risk of unsafe settings - Use only the settings described in this manual.

⚠ WARNING: Risk of tipping over - Variation allowed adjustments can still change the stability of your scooter (tilt back or sideways).

3.1 Tools

To set up the scooter the following tools are needed:

- Wrench set n° 13
- Allen keyset n° 5

3.2 Manner of delivery

The scooter shall be delivered with:

- Frame with armrests, steering unit, rear and front wheels
- Footplate (2x)
- Seat + backrest (2x)
- Batteries, motor (2x)
- Basket
- Rear view mirrors (2x)
- Manual brake
- Accessories
- Instruction manual

3.3 Adjusting the steering unit

The steering unit can be adjusted in to many different positions (stepless) to suit each driver.

- ⚠ **WARNING: Risk of injury - Never adjust the angle while you are driving.**
- ⚠ **WARNING: Risk of injury - Turn the scooter off before you adjust the angle of the steering unit.**
- ⚠ **WARNING: Risk of injury - Do not lean with your whole body on the steering unit.**

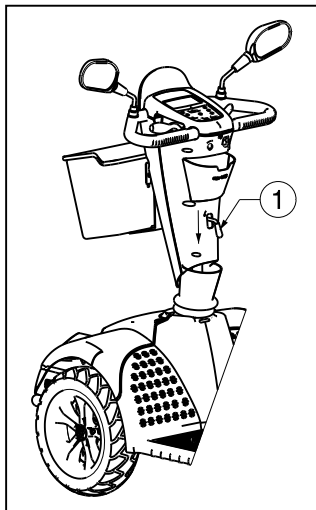

1. Push the lever ① downwards.
2. Adjust the steering unit in the desired position.
3. Release the lever ①.

3.4 Adjusting the seat

- ⚠ **WARNING: Risk of injury - Never perform adjustments while you are driving.**
- ⚠ **WARNING: Risk of injury - Make sure that the seat is locked securely.**

Remove seat (Fig. A)

1. Pull the seat lever ① upwards.
2. Turn the seat ② a little bit and lift the seat out the adjustment bar ⑤.
3. Release the seat lever ①.

Lock the seat in place (Fig. A)

1. Pull the seat lever ① upwards.
2. Place the seat ② on the adjustment bar ⑤ and at the same time keep the seat lever ① pressed in.
3. Release the seat lever ①.
4. Check that the seat is firmly secured.

Swivel seat (Fig. A)

1. Pull the seat lever ① upwards.
2. Turn the seat ② in the desired direction.
3. Release the seat lever ①, and the seat will always stop after 90°.
4. Check that the seat is firmly secured.

Depth adjustment (Fig. A)

1. Pull the seat depth adjustment lever ③ upwards.
2. Move the seat ② forward or backward over the seat depth rails ④.
3. To lock the seat in place, let go of the lever ③ once the seat ② has reached the desired position.
4. Swivel the seat a little until it locks in position.
5. Check the seat is locked securely.

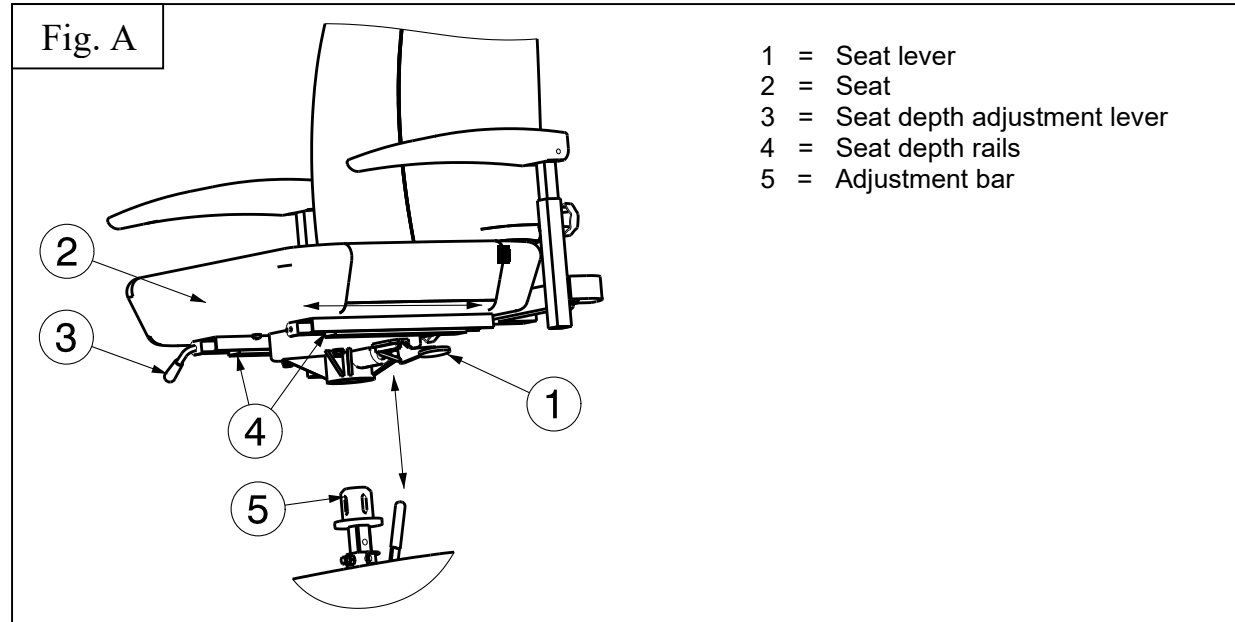

Seat height adjustment (Fig. B)

The seat can be adjusted in 4 different seat heights (increments: 25 mm).

1. Remove the seat ③.
2. Loosen the screw ① a little bit.
3. Remove the safety pin ②.
4. Move the adjustment bar ⑤ upwards/downwards in the receiver ④, and place these in a comfortable seat height.
5. Replace the safety pin ②.
6. Replace the seat ③.
7. Fasten the screw ① and check that the play of the seat is reduced.
8. Check the seat is locked securely.

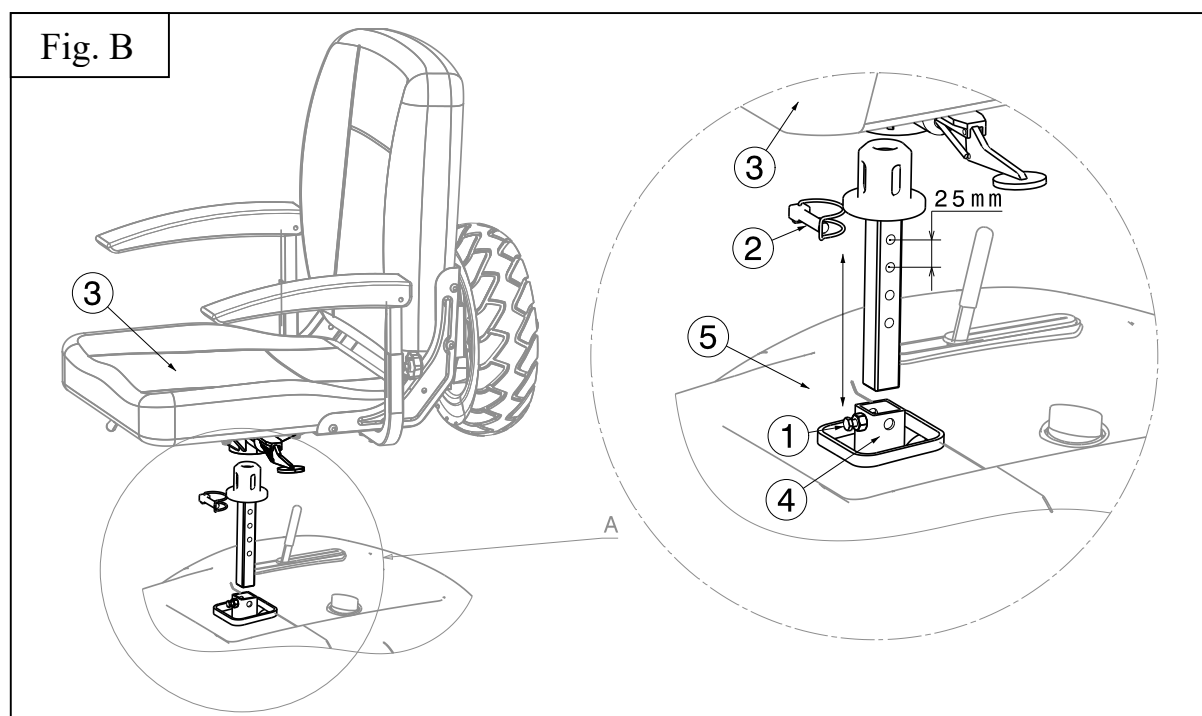

3.5 Adjusting the rear view mirrors

It is possible to adjust the rear view mirrors:

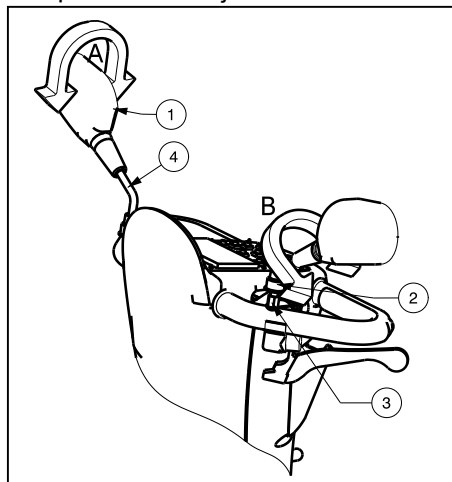

Adjustment 1 (arrow A):

1. Grasp the rear view mirror ①.
2. Rotate the rear view mirror ① in the desired position.

Or

Adjustment 2 (arrow B):

1. Move the cap ② upwards.
2. Loosen the mirror screw ③.
3. Grasp the tube ④ gently.
4. Rotate the tube ④ and put the mirror ① in the desired position.

3.6 Adjusting the armrests

- ⚠ **CAUTION:** Risk of tipping over - Make sure that the armrests are positioned symmetrically from the seat.
- ⚠ **CAUTION:** Risk of injury - Mount the inner tube always with of safe distance of 50 mm in the outer tube.

The armrest can be adjusted in height and depth.

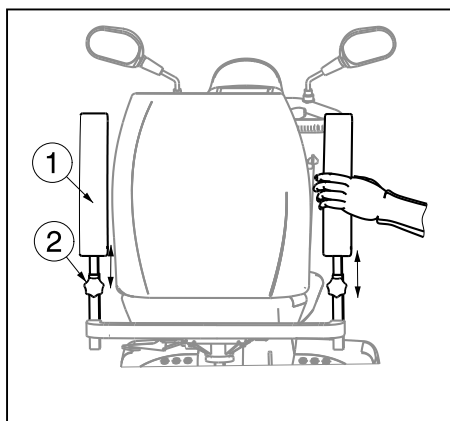

3.6.1 Adjusting height armrests

- ⚠ **CAUTION:** Risk of injury - Do not put your fingers, buckles, clothes, jewelry between the swing away system of the armpad.

1. Fold the armpad ① backwards.
2. Loosen the star knob ②.
3. Grasp the armpad ① as shown in the picture.
4. Move the armpad ① upwards or downwards until the desired height (range: 120 mm stepless).
5. Retighten the star knob ②.
6. Check that the armrest is fixated very well.

3.7 Tyre changing

- ⚠ **CAUTION:** There must be no air in the tube before it can be removed.
- ⚠ **CAUTION:** Risk of damage - If handled improperly, the rim might be damaged.

Note the following before inserting the new tube:

Check the rim bed and the inside wall of the tyre for foreign matter and clean these properly if necessary. Check the condition of the rim bed, especially around the position of the air valve. Please use only genuine original replacement parts. No liability is accepted for damage caused by non-genuine replacement parts. Kindly contact your specialist dealer.

Assembly:

- ⚠ **WARNING:** Risk of injury - Check that the pressure is correct.
- ⚠ **CAUTION:** Risk of injury - Make sure that no objects or body parts are pinched between the tyre and the rim when mounting a tyre.
- ⚠ **WARNING:** Risk of injury - Make sure all screws are firmly secured by hand before driving with your scooter. Screw adhesive (ex. Loctite) should be applied to the screws on the flange. Screw adhesive will only work if the thread is free of grease and particles.

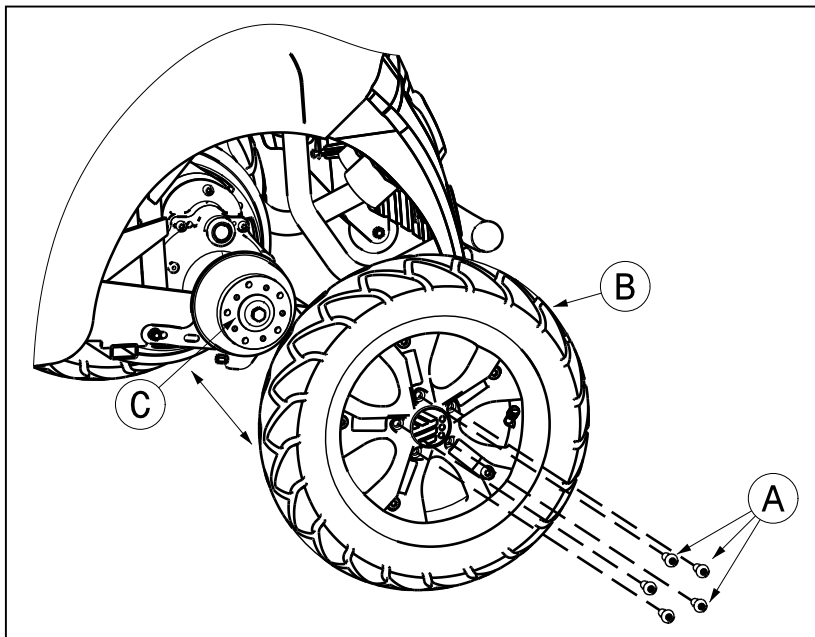

DISMANTLING

1. Unscrew and remove the 5 screws (A) that attach the wheel (B) to the flange (C).
2. Let the air out of the wheel by lightly pressing the pressure pin on the valve (D).
3. Unscrew the 5 screws (E) of the rim. Separate the rim sides.

ASSEMBLY

Insert the partly-filled inner tube into the tyre.

1. Connect the two sides of the rim through the tyres and screw them back again with the 5 screws (E).
2. Put the valve (D) through the hole for it in the rim.
3. Put the wheel (B) back on the flange (C) and secure these connection with the 5 screws (A). Inflate the wheel to the recommended tyre pressure.

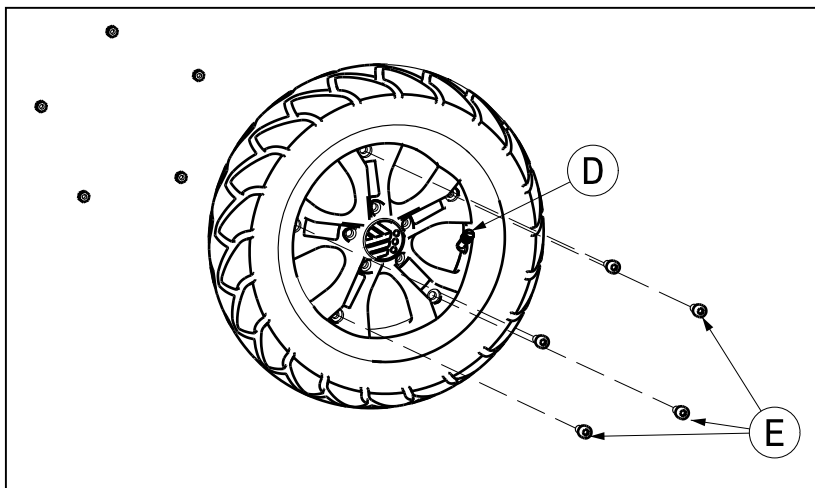

Check all around on both sides that the tube is not pinched between the rim and the edge of the tyre. Lightly push the air valve inwards and pull it out again to make sure that the tyre is positioned properly in the region of the air valve.

To ensure that the wheel is inflated correctly, admit only so much air initially that the tyre can still be easily pushed inwards by using your thumbs. If the check-lines are equidistant from the edge of the rim on both sides of the tyre, then the tyre is centered properly. If not - let out the air and position the tyre afresh. Now the tyre can be inflated to its full operating pressure (note the maximum) and the valve cap should be replaced.

Only an expert can guarantee correct assembly. Work not done by your specialist dealer, would void any warranty claims.

When inflating the tyres, always check that the pressure is correct. The correct pressure is given on the tyre walls.

Use only inflating equipment which complies with regulations and indicates the pressure in bar. We do not accept any liability for damage caused by using wrong inflation equipment or wheels.

3.8 Thermal fuses

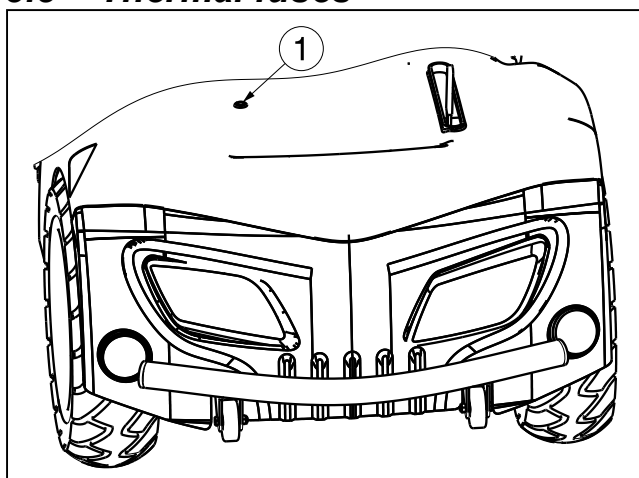

To protect the motor against overload, your scooter have a thermal safety mechanism ① on the rear of your scooter. The thermal fuse will automatically cut the motor to prevent overheating and thus rapid wear and tear or breakdowns. You can access the thermal safety device through a gap in the back of the synthetic cover.

The thermal safety device can go loose if you go up or down slopes that exceed the maximum gradient indicated. Nominal loads that exceed the maximum permitted could also cause the device to jump out. Likewise, if you keep on driving with the engine brake on, it could result in overload. The maximum values not to exceed are indicated in the chapter "Technical Specifications" of the corresponding manual.

To be able to use the scooter again, remove the overload and wait till the motor has cooled off. Then gently press the thermal safety mechanism back in. Your scooter is now ready for use again.

3.9 Anti-tipping

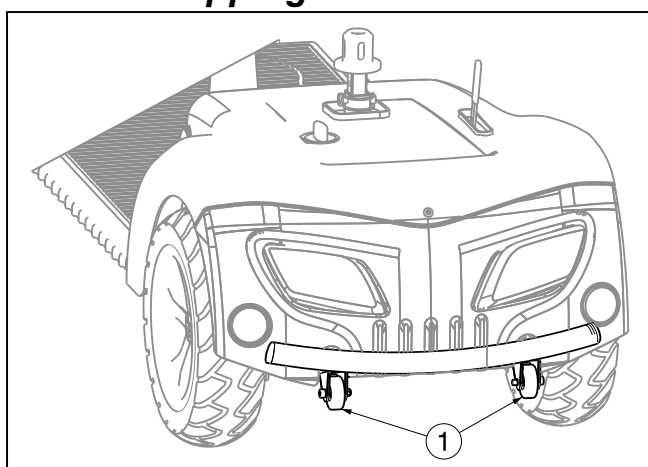

An anti-tipping ① is fixed to the frame of the scooter on the back side. It is not possible to remove these. The anti-tipping is there for your safety. It prevents the scooter from tipping over backward when you drive over small obstacles that do NOT exceed the maximum height specified.

3.10 Changing the battery

⚠ CAUTION: Risk of burns - Do not come in contact with the acid from the batteries. See for a good ventilation of the battery compartment.

The battery shall be changed by trained personnel.

The wiring and charger are well situated in the scooter. Do not attempt to re-locate the wiring by yourself. The improper installation of the wiring may result in pinching the wiring between the battery box, which cause failure to the electronic system of your scooter.

Be sure the battery cables are connected to the right battery.

4 Maintenance

For the maintenance manual of the scooters refer to the Vermeiren website: www.vermeiren.com.

5 Declaration of conformity

The manufacturer or his authorized representative :

VERMEIREN GROUP

Address :

Vermeirenplein 1/15
2920 Kalmthout
Belgium

declares under his sole responsibility that the CE marked devices :

Productgroup:	Scooters
Productgroup (GMDN):	Wheelchair, attendant / occupant, manual / steer, collapsible (GMDN 40855)
Brand:	Vermeiren
Type:	Carpo 2, Carpo 2 Eco, Carpo 2 Sport, Carpo 2 XD, Carpo 2 SE, Carpo Limo

have been classified as class I, according to annex IX MDD 93/42/EEC, rule 12,

and is manufactured in full conformity with the European instructions below - including the latest modifications - and with the national law, that organizes this directions :

Medical devices directive MDD 93/42/EEC: 2007, Annex VII

and is in conformity with the relevant European harmonized standards:

EN 12182: 2012, EN 12184: 2014, EN60601-1-2: 2007, EN 55011: 2009+A1



Vermeiren GROUP NV
Vermeirenplein 1 / 15
2920 Kalmthout
BE

website: www.vermeiren.com

Instructions for specialist dealer

This instruction manual is part and parcel of the product and must accompany every product sold.

Version C, 2020-06

All rights reserved, including translation.

No part of this manual may be reproduced in any form what so ever (print, photocopy, microfilm or any other process) without written permission of the publisher, or processed, duplicated or distributed by using electronic systems.